



RATINGS 400 V - 50 Hz		
Standby	kVA	8,90
	kWe	7,10
Prime	kVA	8,10
	kWe	6,50

### Benefits & features

#### KOHLER premium quality

- Design offices using the latest technical innovations
- Modern fully certified factories
- A cutting edge laboratory
- The generating set, its components and a wide range of options have been fully developed, prototype tested, factory built, and production tested
- Approved for use with HVO (Hydrotreated Vegetable Oil) according to EN15940

#### KOHLER premium performances

- Optimized and certified sound levels
- Reliable power, even in extreme conditions
- Optimized fuel consumption
- Compact footprint
- Best quality of electricity, high starting and loading capacity, according to ISO8528-5
- Robust base frames and high-quality enclosures
- Protection of installations and people
- Approved in line with the most stringent standards

#### Engines

- Premium level engines, in-house or from strong partners
- High power density, small footprint
- Low temperature starting capability
- Long maintenance interval

#### Alternator

- Provide industry leading motor starting capability
- Made in Europe
- Built with a class H insulation and IP23

#### Cooling

- A compact and complete solution using a mechanically driven radiator fan
- Designed or optimized by KOHLER
- High temperature and altitude product capacity available

#### Base frame and enclosure

- High quality steel with enhanced corrosion resistance
- Highly durable QUALICOAT-certified epoxy paint
- Minimum 1000 hours of resistance to salt spray in accordance with ISO12944
- Ergonomic access to allow easy maintenance and connection of the generator
- Robust design optimized for transportation

### GENERAL SPECIFICATIONS

Engine brand	KOHLER KDI
Alternator commercial brand	KOHLER
Voltage (V)	400/230
Standard Control Panel	APM303
Optional control panel	Terminal block
Consumption @ 100% load ESP (L/h)	3
Consumption @ 100% load PRP (L/h)	3
Emission level	Fuel consumption optimization
Type of Cooling	Mechanical driven fan
Performance class	G2

### GENERATOR SETS RATINGS

	Voltage	PH	Hz	Standby Rating			Prime Rating	
				kWe	kVA	Amps	kWe	kVA
K9	415/240	3	50	7,10	8,90	12	6,50	8,10
	400/230	3	50	7,10	8,90	13	6,50	8,10
	380/220	3	50	7,10	8,90	14	6,50	8,10
	240 TRI	3	50	7,10	8,90	21	6,50	8,10
	230 TRI	3	50	7,10	8,90	22	6,50	8,10
	220 TRI	3	50	7,10	8,90	23	6,50	8,10
	220/127	3	50	7,10	8,90	23	6,50	8,10

### DIMENSIONS COMPACT VERSION

Length (mm)	1220
Width (mm)	700
Height (mm)	920
Tank capacity (L)	50
Dry weight (kg)	290

### DIMENSIONS SOUNDPROOFED VERSION

Type soundproofing	NOT AVAILABLE
Length (mm)	1482
Width (mm)	760
Height (mm)	1030
Tank capacity (L)	50
Dry weight (kg)	390
Acoustic pressure level @1m in dB(A) 50Hz (75% PRP)	67
Acoustic pressure level @7m in dB(A) 50Hz (75% PRP)	54

Reference Conditions: 25°C Air Inlet Temperature, 40°C Fuel Inlet Temperature, 100 kPa Barometric Pressure; 10.7 g/kg of dry air Humidity. Intake Restriction set to maximum allowable limit for clean filter; Exhaust Back pressure set to maximum allowable limit; Fuel density at 0.85 kg/L.

Data was taken from a single engine test according to the test methods, fuel specification and reference conditions stated above and is subjected to instrumentation and engine-to-engine variability. Test conducted with alternate test methods, instrumentation, fuel or reference conditions can yield different results. Data and specifications subject to change without notice.

### Engine

#### General

Engine brand	KOHLER KDI
Engine ref.	KDW1003 *
Air inlet system	Atmo
Fuel	Diesel Fuel/HVO
Emission level	Fuel consumption optimization
Cylinder configuration	L
Number of cylinders	3
Displacement (l)	1,03
Bore (mm) * Stroke (mm)	75 * 77,60
Compression ratio	22,8 : 1
Speed 50Hz (RPM)	1500
Maximum stand-by power at rated RPM (kW)	8,50
Frequency regulation, steady state (%)	+/- 2.5%
Injection Type	Indirect
Governor type	Mechanical
Air cleaner type, models	Dry

#### Fuel system

Maximum fuel pump flow (l/h)	50
------------------------------	----

#### Consumption with cooling system

Fuel consumption @ ESP Max Power (l/h)	2,70
Fuel consumption @ PRP Max Power (l/h)	2,50
Fuel consumption @ 75% of PRP Power (l/h)	1,90
Fuel consumption @ 50% of PRP Power (l/h)	1,30

### Emissions

#### Lubrication System

Oil system capacity including filters (l)	2,40
Min. oil pressure (bar)	1,40
Max. oil pressure (bar)	7
Oil sump capacity (l)	2,30
Oil consumption 100% ESP 50Hz (l/h)	0,04

#### Air Intake system

Max. intake restriction (mm H2O)	200
Combustion air flow (l/s)	12,80

#### Exhaust system

	PRP	ESP
Heat rejection to exhaust (kW)		9
Exhaust gas temperature (°C)		440
Exhaust gas flow (L/s)		30,70
Max. exhaust back pressure (mm H2O)	750	

\* Engine reference may be partially modified depending on genset application, options selected by the customer and lead time required.

### Alternator Specifications

Alternator commercial brand	KOHLER
Kohler Alternator description	KH00260TO4N
Number of pole	4
Number of bearing	Single Bearing
Technology	Brushless
Indication of protection	IP23
Insulation class	H
Number of wires	12
AVR Regulation	Yes
Coupling	Direct
Capacity for maintaining short circuit at 300% of rated current for 10 s	Yes

### Application data

Overspeed (rpm)	2250
Power factor (Cos Phi)	0,80
Voltage regulation at established rating (+/- %)	1
Wave form : NEMA=TIF	<45
Wave form : CEI=FHT	<2
Total Harmonic Distortion in no-load DHT (%)	2,7
Total Harmonic Distortion, on linear load DHT (%)	2,8
Recovery time (Delta U = 20% transient) (ms)	200

### Performance datas

Continuous Nominal Rating 40°C (kVA)	8
Unbalanced load acceptance ratio (%)	8

Peak motor starting (kVA) based on x% voltage dip power factor at 0.3

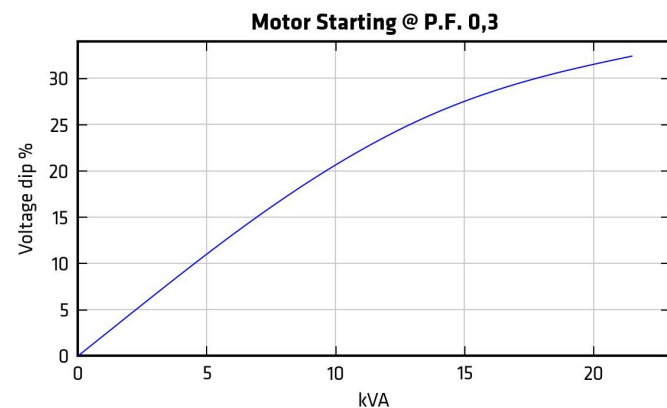

### Alternator Standard Features

- All models are brushless, rotating-field alternators
- NEMA MG1, IEEE, and ANSI standards compliance for temperature rise and motor starting
- The AVR voltage regulator provides superior short circuit capability
- Self-ventilated and dip proof construction
- Superior voltage waveform

*Note: See Alternator Data Sheets for alternator application data and ratings, efficiency curves, voltage dip with motor starting curves, and short circuit decrement curves.*

**Dimensions compact version**

---

Length (mm) * Width (mm) * Height (mm)	1220 * 700 * 920
Dry weight (kg)	290
Tank capacity (L)	50

**M125 - Dimensions soundproofed version**

---

Length (mm) * Width (mm) * Height (mm)	1482 * 760 * 1030
Dry weight (kg)	390
Tank capacity (L)	50
Acoustic pressure level @1m in dB(A) 50Hz (75% PRP)	67
Sound power level guaranteed (Lwa) 50Hz (75% PRP)	85
Acoustic pressure level @7m in dB(A) 50Hz (75% PRP)	54



**Basic  
terminal block**

It is used as a basic terminal block for connecting a control unit. Offers the following functions:

- emergency stop button
- customer connection terminal block
- CE certified

**APM303**

The APM303 is a versatile unit which can be operated in manual or automatic mode. It offers the following features:

- Measurements: phase-to-neutral and phase-to-phase voltages, fuel level (In option : active power currents, effective power, power factors, Kw/h energy meter, oil pressure and coolant temperature levels)
- Supervision: Modbus RTU communication on RS485
- Reports: (In option : 2 configurable reports)
- Safety features: Overspeed, oil pressure, coolant temperatures, minimum and maximum voltage, minimum and maximum frequency (Maximum active power P<66kVA)
- Traceability: Stack of 12 stored events

For further information, please refer to the data sheet for the APM303

## STANDARD SCOPE OF SUPPLY

All our gensets are fitted with:

- Industrial water cooled DIESEL engine
- Electric starter & charge alternator
- Standard air filter
- Schneider or ABB electric circuit breaker, adapted to the short-circuit current of the generating set
- Single bearing alternator IP 23 T° rise/ insulation to class H/H
- Welded steel base frame with 85% vibration attenuation mounts
- 4 lifting points on the chassis, lifting bar on the top included from 165 kVA ESP or optional
- highly durable QUALICOAT certified epoxy paint
- frame height optimized to allow it to be moved safely by forklift
- enclosure made of new high-quality European steel with enhanced corrosion resistance
- IP 64 locks, made from stainless materials
- enclosures and base frames tested and analyzed by the French Corrosion Institut
- 100% of tanks tested for permeability
- Personal protection ensured by protective grilles on hot and rotating parts
- Separate 9 dB(A) silencer
- Fuel tank welded inside the genset frame
- Retention bund included for gensets up to 110 kVA ESP
- Charged DC starting battery with electrolyte
- Emergency stop button on the outside
- Flexible fuel lines & lub oil drain cock
- Exhaust outlet with flexible and flanges
- User's manual (1 copy)
- Packing under plastic film
- Delivered with oil and antifreeze liquid

## CODES AND STANDARDS

Engine-generators set is designed and manufactured in facilities certified to standards ISO9001:2015 & ISO14001:2015. The generator sets and its components are prototype-tested, factory built and production tested and are in compliance with the relevant standards:

- Machinery Directive 2006/42/EC of May 17th 2006
- EMC Directive 2014/30/UE
- Safety objectives set out in the Low Voltage Directive 2014/35/UE
- EN ISO 8528-13, EN 60034-1, EN 61000-6-1, EN 61000-6-2, EN 61000-6-3, EN 55011, EN 1679-1 et EN 60204-1

## POWER RATINGS DEFINITION according to ISO8528-1 (2018-02 edition) and ISO-3046-1

**Emergency Standby Power (ESP):** The standby rating is applicable to varying loads for the duration of a power outage. There is no overload capability for this rating. Average load factor per 24 hours of operation is <70%.

**Prime Power (PRP):** At varying load, the number of generator set operating hours is unlimited. A 10% overload capacity is available for one hour within 12 hour of operation. Average load factor per 24 hours of operation is <70%.

**TERMS OF USE**

According to the standard, the nominal power assigned by the genset is given for 25°C Air Inlet Temperature, of a barometric pressure of 100 kPa (100 m A.S.L), and 30% relative humidity. For particular conditions in your installation, refer to the derating table.

**WARRANTY INFORMATIONS**

Standard Warranty Period:

- for Products in "back-up" service
  - o 30 months from the date the Product leaves the plant
  - o 24 months from the Product's commissioning date
  - o 1,000 running hours

The warranty expires when one of the above conditions is met.

- for Products in "prime" or "continuous" service (continuous supply of electricity, either in the absence of any normal electricity grid or to complement the grid),
  - o 18 months from the date the Product leaves the plant
  - o 12 months from the Product's commissioning date
  - o 2,500 running hours

The warranty expires when one of the above conditions is met.

For more details regarding conditions of application and scope of the warranty please refer to our General "terms & conditions of sales".